

DESCRIZIONE:

ANTARES II° è adatto per applicazioni su veicoli dotati di impianto idraulico come ad esempio macchine movimento terra, gru telescopiche, carrelli elevatori, mezzi ferroviari ecc....

ANTARES II° è composto da:

Motore idraulico ad ingranaggi da 11,23 cm³ con connessioni da 1/2"

Compressore SANDEN SD7B10 cilindrata 100 cc

Supporto compressore e motore con silent block

DESCRIPTION:

ANTARES II is suitable for application on vehicles with hydraulic system for example hearth-movers machinery, cranes, telescopic handlers, lift trucks, railway machinery and so on.

ANTARES II is composed by:

Hydraulic engine with 11.23cm³ gears with 1/2" connections

SD7B10 SANDEN compressor with engine capacity of 100cc

Compressor bracket and silent-block engine

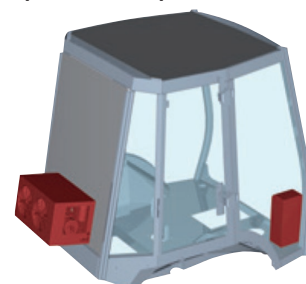

Esempio di possibili combinazione

Example of possible combination

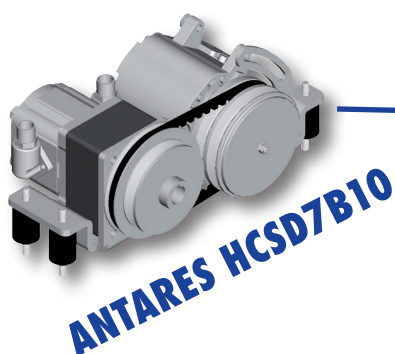

COMPRESSORE IDRAULICO HYDRAULIC COMPRESSOR MOTOR UNIT

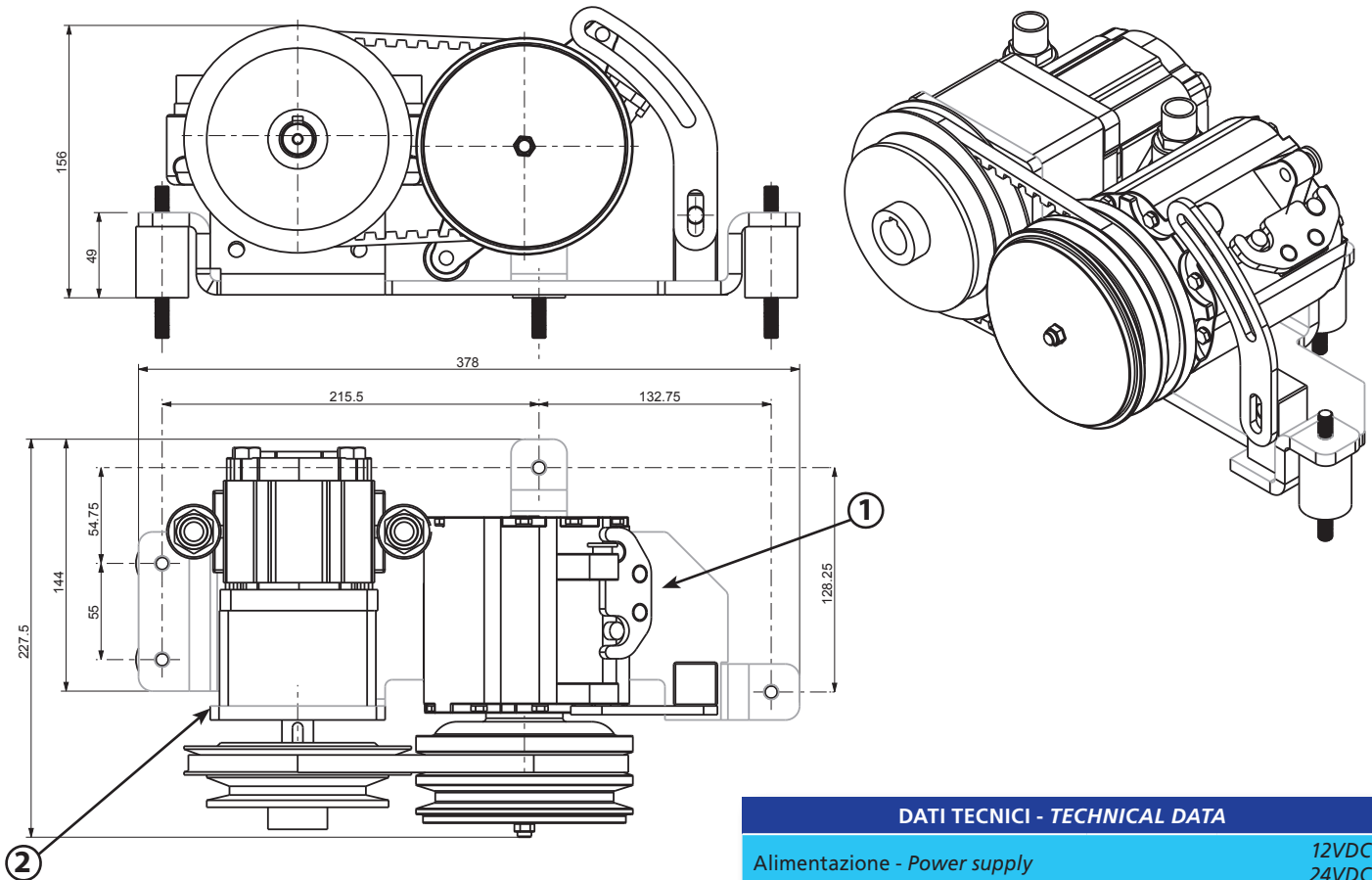

DATI TECNICI - TECHNICAL DATA

Alimentazione - Power supply	12VDC 24VDC
Motore idraulico - Hydraulic motor	Maximum 200 Bar Pressure Maximum 55 Liters per minute
Peso - Weight	12 Kg

CODICE PART NUMBER	VERSIONE VERSION
U27MM	GRUPPO IDRAULICO 12VDC / 12VDC HYDRAULIC GROUP
U28MM	GRUPPO IDRAULICO 24VDC / 24VDC HYDRAULIC GROUP

DESCRIZIONE CONNESSIONI - CONNECTIONS DESCRIPTIONS

- ① Compressore SD7B10 100 cm³
 Compressor SD7B10 100 cm³
- ② Motore idraulico 11,23 cm³ con connessioni 1/2"
 Hydraulic motor 11,23 cm³ with logons 1/2"